

# SENOFEE

ITEM NO: HVT116T



## Current Type Single-axis Inclinometer

Email: [info@senofee.com](mailto:info@senofee.com) / <http://www.senofee.com>

## General Description

HVT116T is an analog current output sensor that allows the customer to calculate the current product tilt angle from the analog current output. The product adopts precision MEMS micro-electromechanical import technology, and adopts the latest packaging technology to be waterproof. The product is small in size and low in power consumption. The product is easy to use and easy to install. It is a solar energy, wind energy engineering machinery equipment, automation equipment and other industries. The best choice for field angle controllers (products can be customized).

## Specifications

Accuracy: 0.1°	Resolution: 0.1°	Protection rating: IP67
Measuring axis: Y-axis		Measuring range: $\pm 90^\circ$
Power supply voltage range: 9-35v		Output signal: 4-20mA , 0~20mA
Anti-vibration performance: >2000g		Wide temperature working: $-40^\circ\text{C} \sim +85^\circ\text{C}$
Store temperature : $-55^\circ\text{C} \sim +100^\circ\text{C}$		
Zero temperature drift ( $-40^\circ\text{C} \sim 85^\circ\text{C}$ ): $\pm 0.005^\circ$		

## Applications

- 1: Industrial automatic leveling
- 2: Medical equipment
- 3: Solar automatic tracking
- 4: Tower tilt monitoring
- 5: Lifting angle control of cranes
- 6: Structural deformation monitoring
- 7: Measuring and mapping instruments
- 8: Military equipment automation



## Electrical parameters

Parameters	conditions	Min	Standard	Max	Unit
power supply		5	12 24	36	V
Working current		15	30	40	mA
Working temperature		-40		+85	°C
Store temperature		-55		+100	°C

## Technical Data

Parameters	conditions	HVT116T-10	HVT116T-30	HVT116T-60	HVT116T-90
Measuring rang		±10°	±30°	±60°	±90°
Measuring axis		Y	Y	Y	Y
Resolution		0.1°	0.1°	0.1°	0.1°
Zero temperature coefficient	-40°C~85°C	0.01°/°C	0.01°/°C	0.01°/°C	0.01°/°C
Absolute accuracy		0.1°	0.15°	0.2°	0.3°
Zero Position	0° Output	2.5V	2.5V	2.5V	2.5V
Power on time		<3S	<3S	<3S	<3S
Output frequency	5-100HZ	Optional	Optional	Optional	Optional
Baud rate	2400-115200	Optional	Optional	Optional	Optional
Shockproof	2000g.0.5ms、3Times/Axis(half sinusoid)				
Average no reason Obstacle time MTBF	≥800000hours/times				
Insulation resistance	≥100MΩ				
Output signal	4-20mA ,0~20mA				
Weight	100g(without cable)				

This Technical data only list ± 10 °, ± 30 °, ± 60 °, ± 90 ° series for reference, other measuring range please refer to the adjacent parameters.

## Key words

**Resolution :** Refers to the sensor in measuring range to detect and identify the smallest changed value.

**Absolute accuracy :** Refers to in the normal temperature circumstances, the sensor absolute linearity, repeatability, hysteresis, zero deviation, and transverse error comprehensive error.

**Response time :** Refers to the sensor in an angle change, the sensor output value reached the standard time required.

## Mechanical Parameters

Connectors	1.2m lead cable ( standard )
Protection glass	IP67
Enclosure material	Aluminum Oxide
Installation	4*M4 screws

## Ordering information

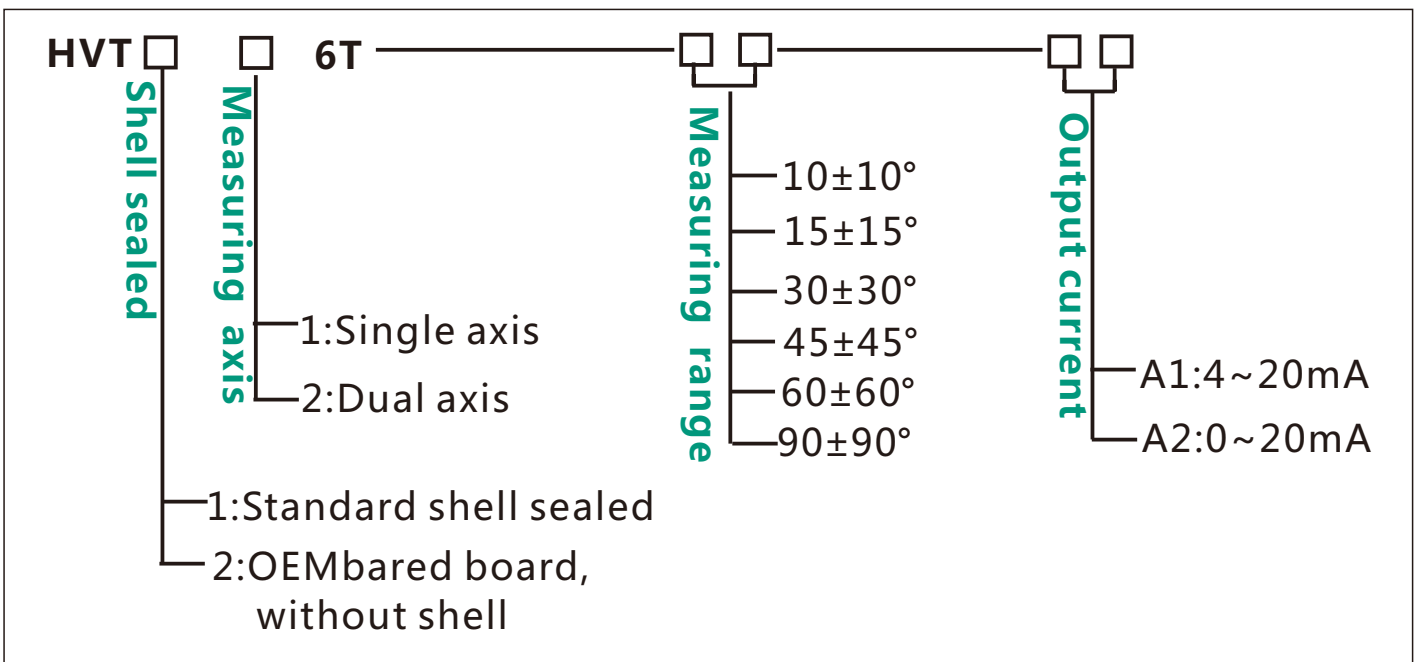

E.g : HVT **11** 6 T -**10**-**A1** : standard/single axis/±10° Measuring range /4mA-20mA output current

### Electrical Connection

Line color	RED	BLACK	GREEN
function	DC 9~36V	GND Power Negative	Y axis

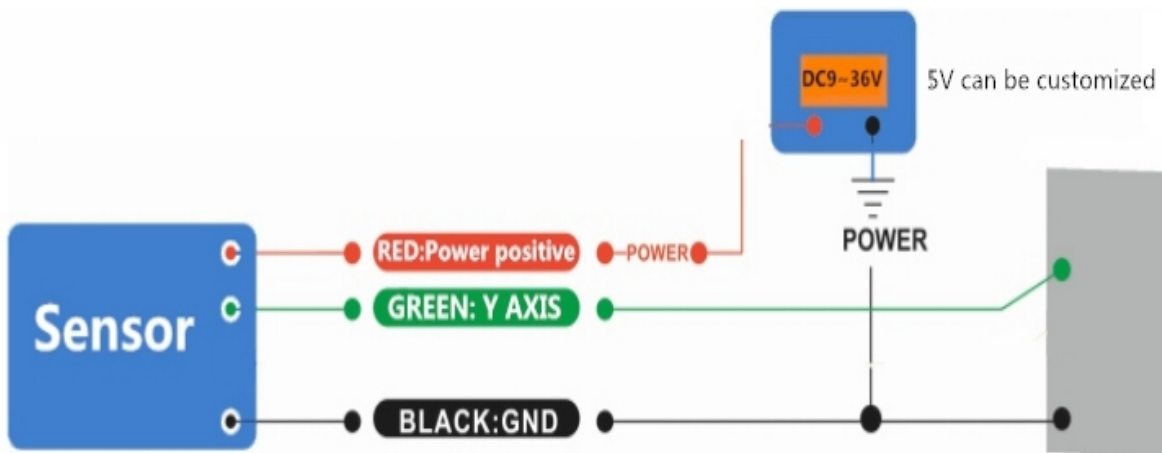

### Working Principle

Adopt the European import of core control unit, using the capacitive micro pendulum principle and the earth gravity principle, when the the inclination unit is tilted, the Earth's gravity on the corresponding pendulum will produce a component of gravity, corresponding to the electric capacity will change, by enlarge the amount of electric capacity , filtering and after conversion then get the inclination.

### Product size chart

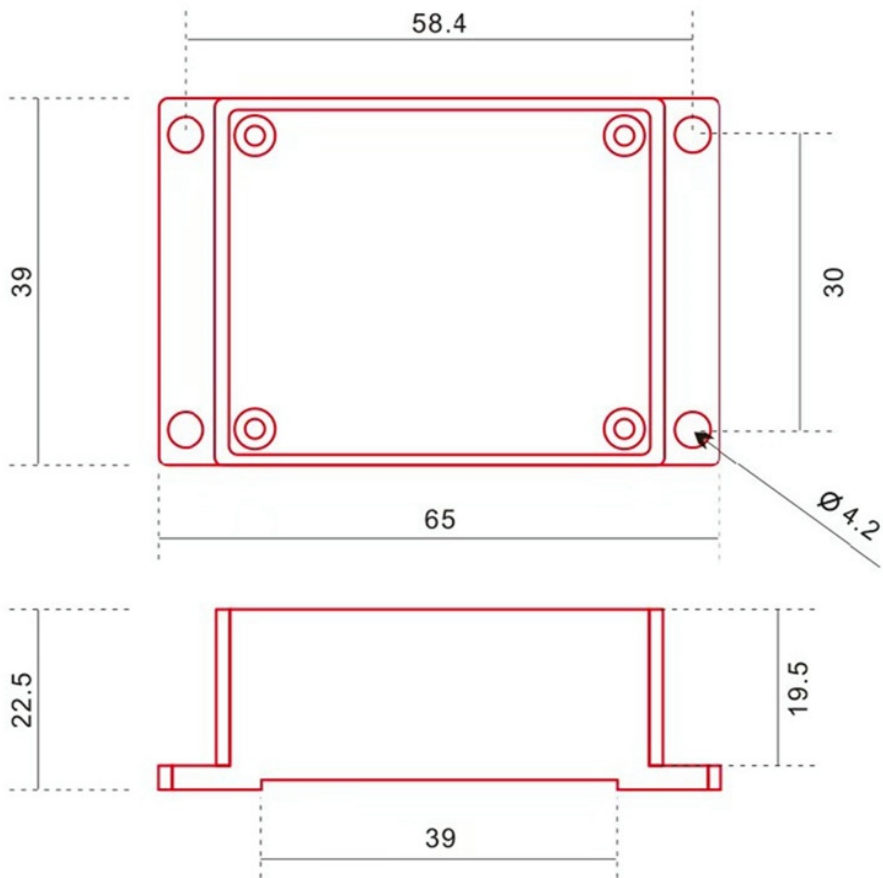

### Measuring direction

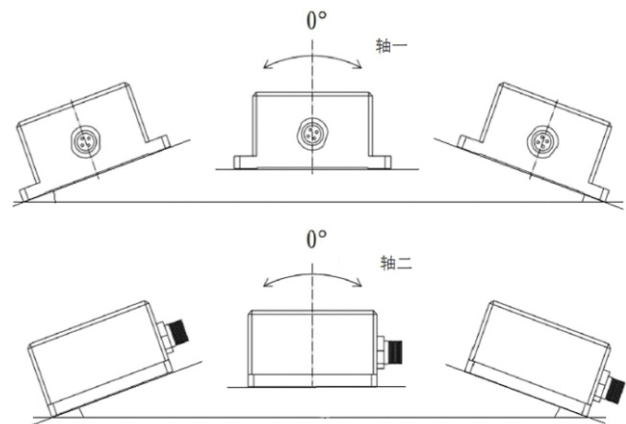
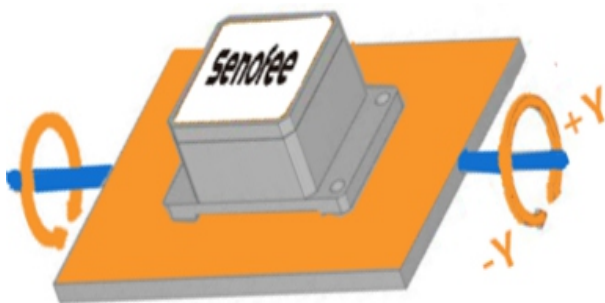

## Production installation notes:

Please follow the correct way to install tilt sensor, incorrect installation can cause measurement errors, with particular attention to the "surface", "line": :

- 1 ) The Sensor mounting surface and the measured surface must be fixed closely, smoothly, stability, if mounting surface uneven likely to cause the sensor to measure the angle error. See Figure Pic.AB
- 2) The sensor axis and the measured axis must be parallel ,the two axes do not produce the angle as much as possible. See Figure Pic.CD :

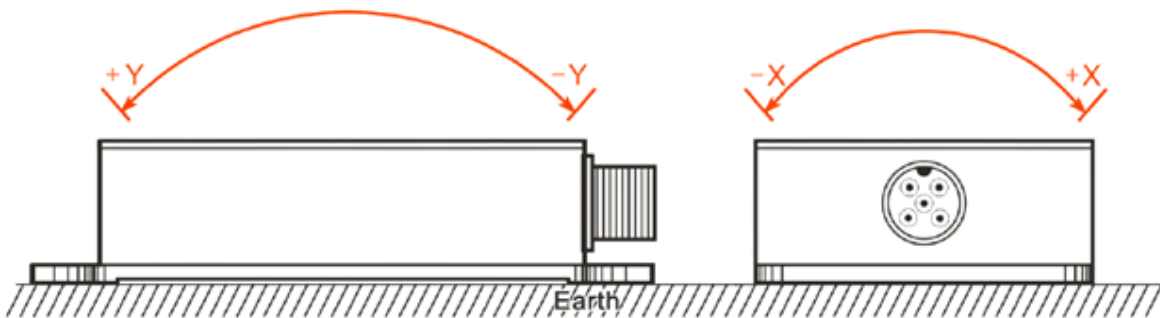

The axis of the sensor must be parallel to the axis to be measured, and the two axes should not be angled as much as possible.

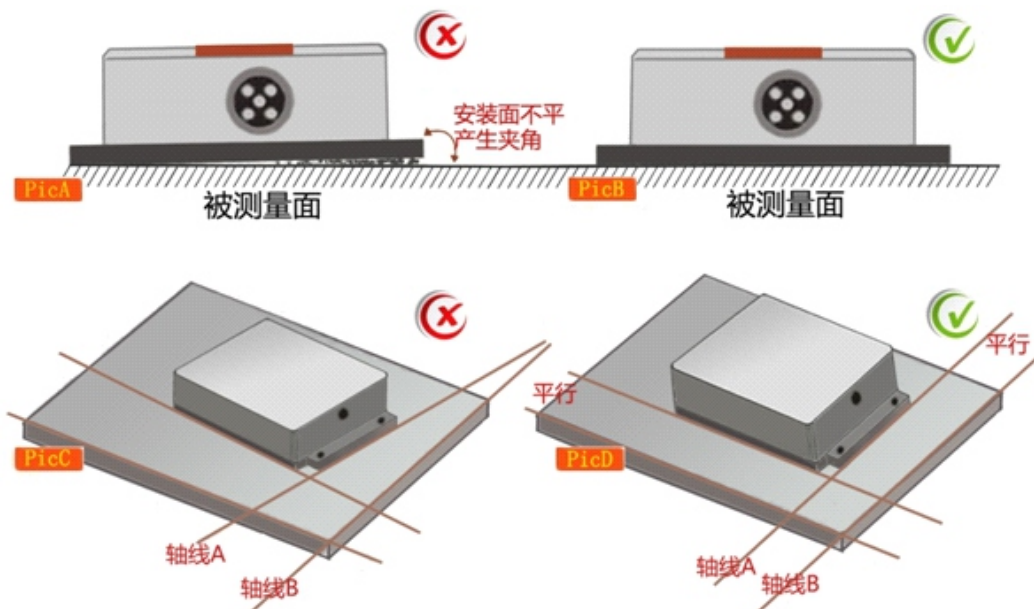

The mounting surface of the sensor must be tight, flat and stable when it is fixed to the surface to be measured.

# SENOFEE

ITEM NO: HVT116T

## **Current Type Single-axis Inclinometer**

Email: [info@senofee.com](mailto:info@senofee.com) / <http://www.senofee.com>