

SENOFEE

ITEM NO: HVS:110T



Digital Type Single-axis Inclinometer

Email: info@senofee.com / <http://www.senofee.com>

General Description

HVS110T series tilt module is a low power consumption and high performance tilt module. The MEMS tilt measurement unit imported from Europe is used inside. It has a built-in industry standard MCU unit and integrates advanced filtering algorithms to ensure the performance of each module. Consistency. HVS series inclination module can select the appropriate output interface according to the actual situation of the customer. It is the best choice for industrial automation control, leveling adjustment, and dam bridge detection. In addition, HVS series products can be based on customers The actual needs to be customized.

Specifications

Accuracy: 0.01°	Resolution: 0.01°	Protection rating: IP67
Measuring axis: Y-axis		Measuring range: ±90°
Power supply voltage range: 9-35v		Output signal:RS485、 RS232
Anti-vibration performance: >2000g		Wide temperature working: -40°C ~ +85°C
Store temperature : -55°C~+100°C		
Zero temperature drift (-40 ° C ~ 85 ° C): ± 0.005 °		

Applications

- | | |
|--------------------------------------|--------------------------------------|
| 1: Industrial automatic leveling | 2: Medical equipment |
| 3: Solar automatic tracking | 4: Tower tilt monitoring |
| 5: Lifting angle control of cranes | 6: Structural deformation monitoring |
| 7: Measuring and mapping instruments | 8: Military equipment automation |



Electrical parameters

Parameters	conditions	Min	Standard	Max	Unit
power supply		5	12 24	36	V
Working current		15	30	40	mA
Working temperature		-40		+85	°C
Store temperature		-55		+100	°C

Technical Data

Parameters	conditions	HVS110T-10	HVS110T-30	HVS110T-60	HVS110T-90
Measuring rang		±10°	±30°	±60°	±90°
Measuring axis		Y	Y	Y	Y
Resolution		0.01°	0.01°	0.01°	0.01°
Zero temperature coefficient	-40°C~85°C	0.005°/°C	0.005°/°C	0.005°/°C	0.005°/°C
Absolute accuracy		0.01°	0.015°	0.02°	0.03°
Zero Position	0° Output	2.5V	2.5V	2.5V	2.5V
Power on time		<3S	<3S	<3S	<3S
Output frequency	5-100HZ	Optional	Optional	Optional	Optional
Baud rate	2400-115200	Optional	Optional	Optional	Optional
Shockproof	2000g.0.5ms、3Times/Axis(half sinusoid)				
Average no reason Obstacle time MTBF	≥800000hours/times				
Insulation resistance	≥100MΩ				
Output signal	RS232、RS485				
Weight	100g(without cable)				

This Technical data only list ± 10 °, ± 30 °, ± 60 °, ± 90 ° series for reference, other measuring range please refer to the adjacent parameters.

Key words

Resolution : Refers to the sensor in measuring range to detect and identify the smallest changed value.

Absolute accuracy : Refers to in the normal temperature circumstances, the sensor absolute linearity, repeatability, hysteresis, zero deviation, and transverse error comprehensive error.

Response time : Refers to the sensor in an angle change, the sensor output value reached the standard time required.

Mechanical Parameters

Connectors	1.2m lead cable (standard)
Protection glass	IP67
Enclosure material	Aluminum Oxide
Installation	4*M4 screws

Ordering information

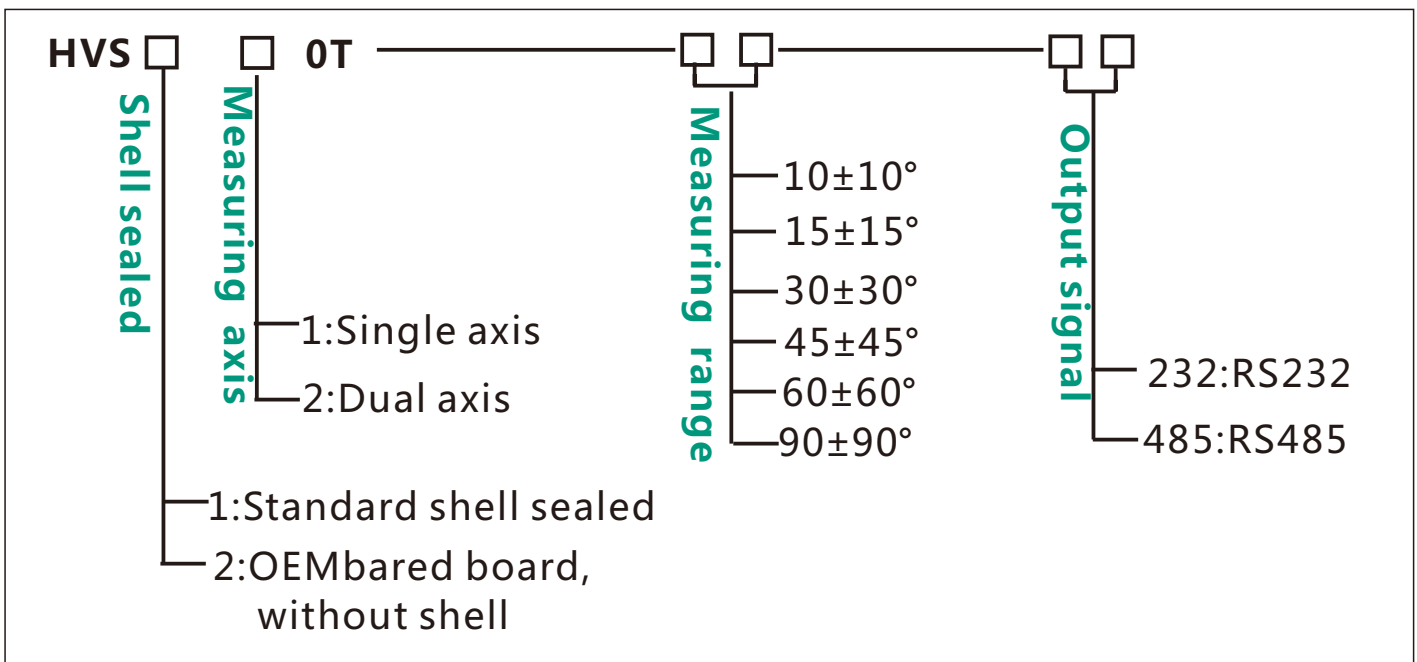

E.g : HVS **110T-10-232** : standard/ Single axis/ $\pm 10^\circ$ Measuring range /RS232 output

Electrical Connection

Line color	RED	BLACK	YELLOW	BLUE
function	DC 9V~36V Power positive	GND Power Negative	RS232(RXD) RS485(D+)	RS232(TXD) RS485(D-)

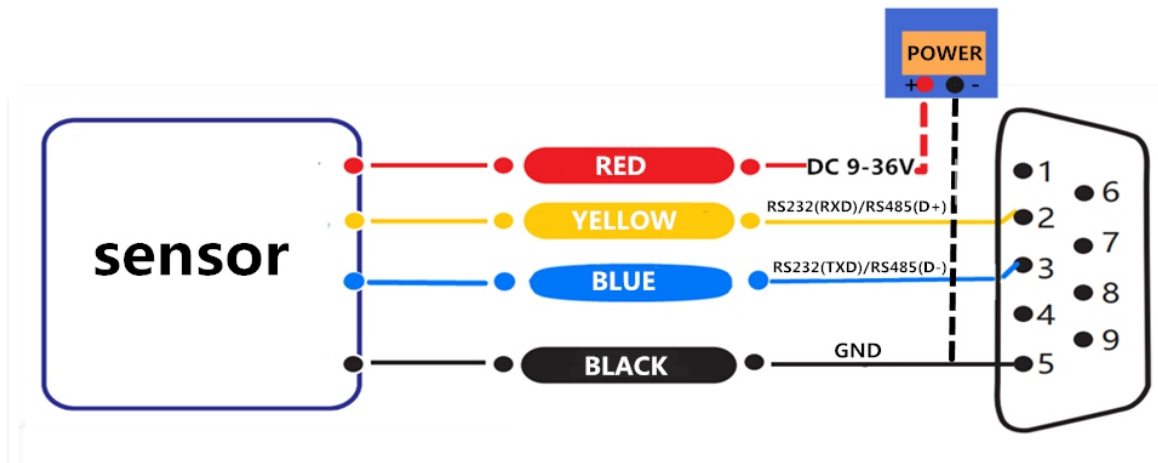

Working Principle

Adopt the European import of core control unit, using the capacitive micro pendulum principle and the earth gravity principle, when the the inclination unit is tilted, the Earth's gravity on the corresponding pendulum will produce a component of gravity, corresponding to the electric capacity will change, by enlarge the amount of electric capacity , filtering and after conversion then get the inclination.

Product size chart

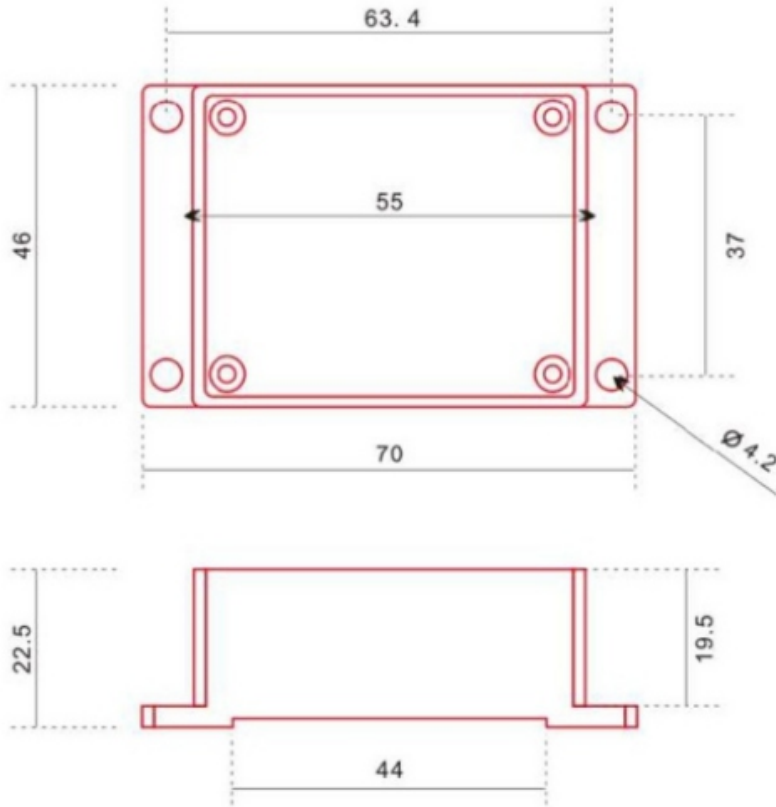

Measuring direction

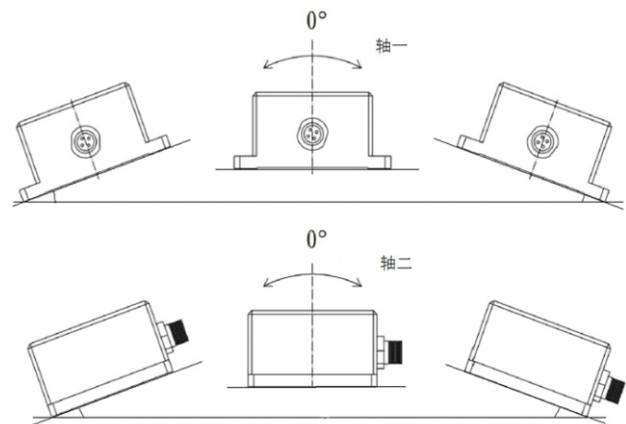
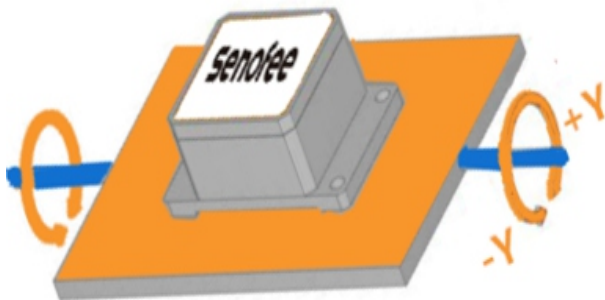

Production installation notes:

Please follow the correct way to install tilt sensor, incorrect installation can cause measurement errors, with particular attention to the "surface", "line":

- 1) The Sensor mounting surface and the measured surface must be fixed closely, smoothly, stability, if mounting surface uneven likely to cause the sensor to measure the angle error. See Figure Pic.AB
- 2) The sensor axis and the measured axis must be parallel, the two axes do not produce the angle as much as possible. See Figure Pic.CD :

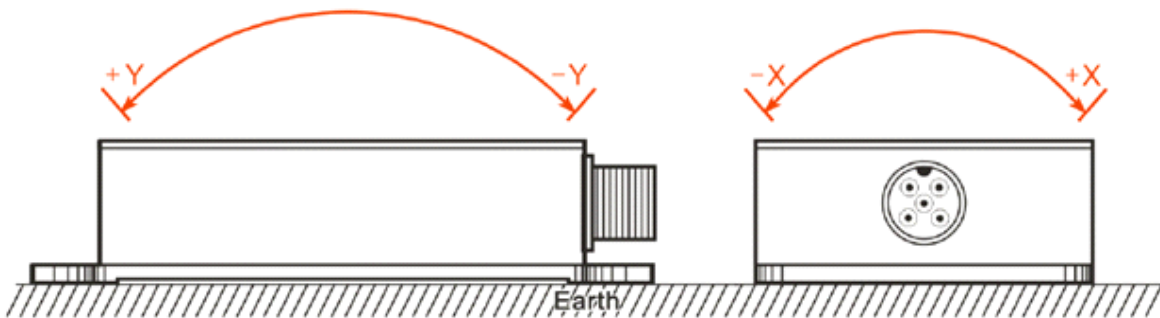

The axis of the sensor must be parallel to the axis to be measured, and the two axes should not be angled as much as possible.

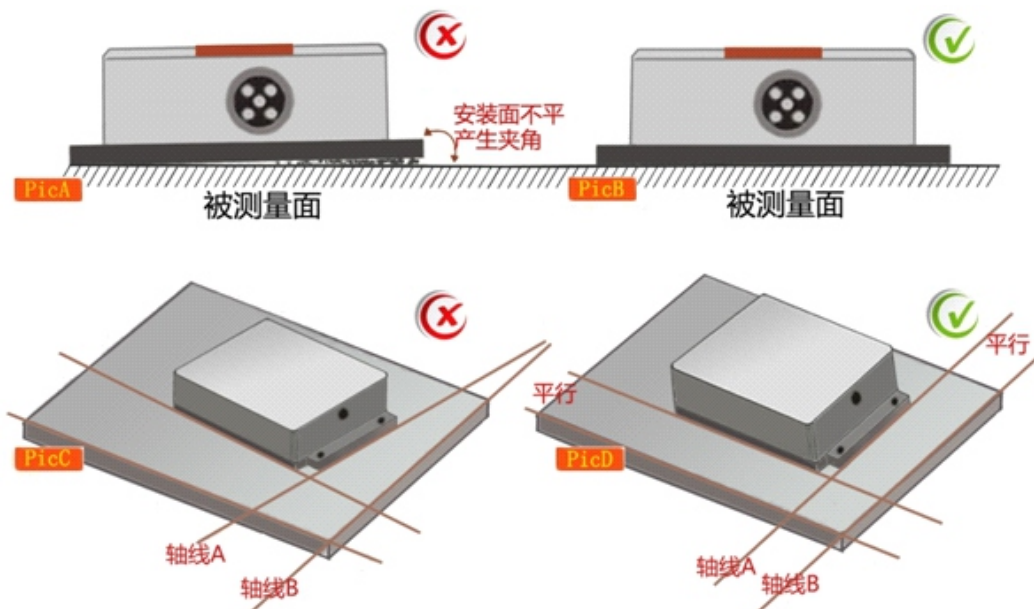

The mounting surface of the sensor must be tight, flat and stable when it is fixed to the surface to be measured.

SENOFEE

ITEM NO: HVS110T

Digital Type Single-axis Inclinometer

Email: info@senofee.com / <http://www.senofee.com>